

HERBOLD



Herbold Dryer HVT

The HVT dryer series has been developed for particularly gentle and energy-saving drying. The machine is used in the recycling of regrind, especially of hollow bodies and PET bottles, polyolefins and other plastics.

The special design feature is the vertical rotor shaft, which ensures longer dwell time and space-saving installation compared to the horizontal arrangement.

The design of the rotor and the housing has been optimised in terms of minimisation of fine components. This largely counteracts the damage caused to flakes particularly in the processing of PET bottles, by splicing and roughening at the cut edges.

A further significant advantage has been achieved in the development of the machine concept: a huge saving of energy. While one or two-stage drying processes with about 90 kW were previously used for the drying of PET flakes at a throughput of 2.5-3 t/h, drive performances of only 30-45 kW are required today.

The dryers of the HVT series work on the principle of centrifugal drying: The material is accelerated against a screened stator surface, and simultaneously transported from bottom to top by the arrangement of the rotor paddles.

The loading is carried out by a horizontal drainage screw, which separates most of the surface moisture before entry into the dryer.

Particular value has been placed on ease of accessibility for maintenance purposes: generously dimensioned fold-open maintenance doors secured by quick-fastenings allow rapid access to the interior.

Optimum protection against wear is provided as standard: the paddles on the rotor are replaceable, the screens can be changed quickly and the endangered areas in the housing are equipped with replaceable wear plates.

The dryers of the HVT series are available as standard in stainless steel or normal steel versions.

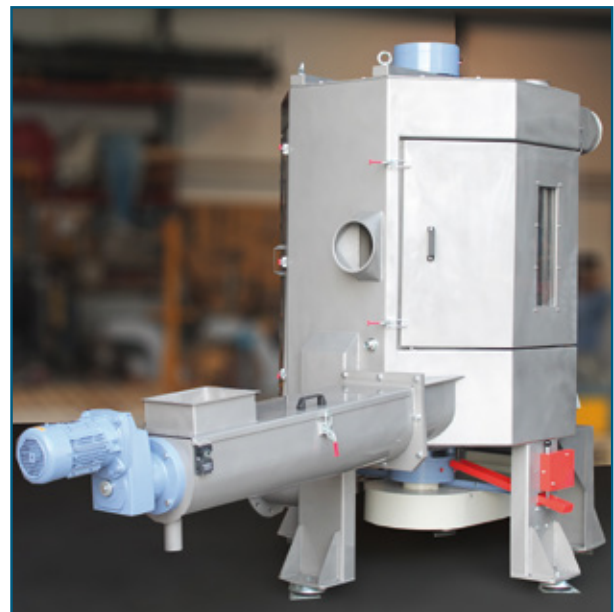
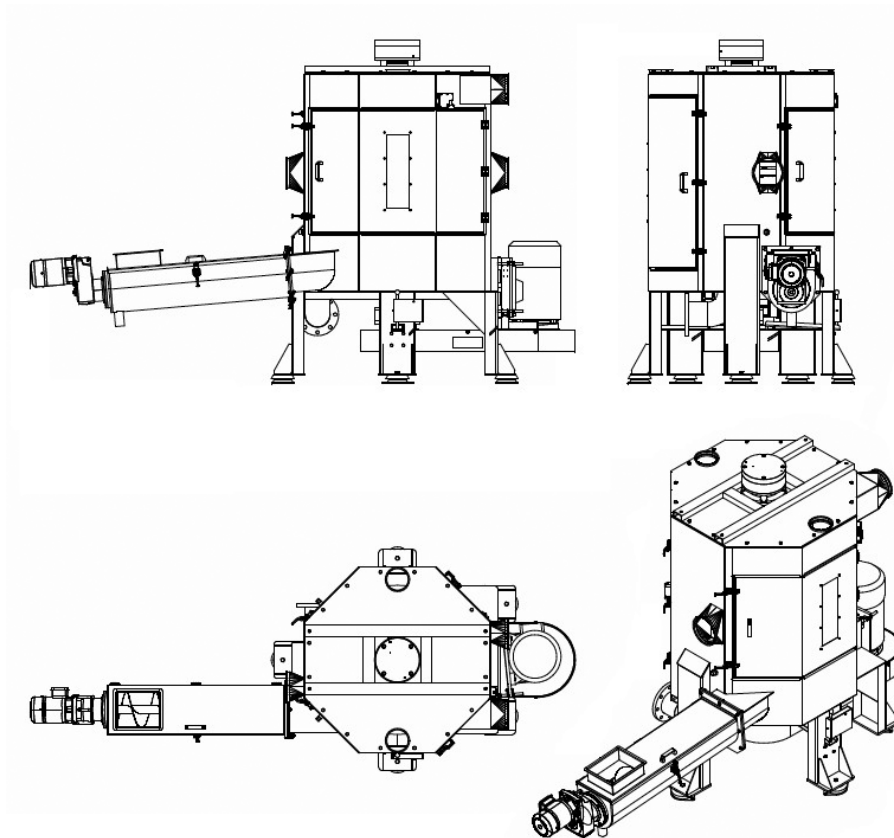

Fig.1: Herbold dryer HVT 90-150

Technical data:				
Model	50/100	90/150	120/230	120/360
Screen cage diameter	500 mm	900 mm	1200 mm	1200 mm
Working length	1200 mm	1450 mm	2300 mm	3600 mm
Drive, kW	5.5 - 22	15 - 45	30 - 90	45 - 110
Drive, HP	7.5 - 30	20 - 75	50 - 150	75 - 250
Throughput up to (t/h)				
Hard plastics	1.0	2.0 - 3.0	3.5 - 5.0	3.5 - 8.0
PET flakes	0.8 - 1.2	2.5 - 3.5	3.5 - 5.0	3.5 - 8.0



Our Product Range

- Guillotines
- Shredders
- Hammer mills
- Granulators
- Pulverizing systems
- Washing systems & components
- Plastcompactors/agglomerators

Herbold Meckesheim GmbH

Industriestr. 33
 74909 Meckesheim
 Postfach 1218
 74908 Meckesheim
 Deutschland
 Tel.: + 49 (0) 6226/932-0
 Fax: + 49 (0) 6226/932-495
 E-Mail: herbold@herbold.com
 Internet: www.herbold.com

Our subsidiary:

Herbold Meckesheim USA Resource Recycling Systems Inc.

130 Industrial Drive
 North Smithfield, RI 02896, USA
 P.O. Box 239
 Slatersville, RI 02876, USA
 Tel.: +1 401 597/5500
 Toll-free (US/CDN): +1 888/612 RRSI (7774)
 Fax: +1 401 597/5535
 E-Mail: info@herboldusa.com
 Internet: www.herboldusa.com