

HERBOLD



Thermal Dryer

TNT 500 dryer:

The material is being conveyed into the stainless steel cyclone, and discharged through the bottom opening into the dryer via rotary airlock valve.

Below the rotary airlock valve, ambient air is sucked into the system through a heat exchanger. To create the necessary temperature we do offer several alternatives:

- electrical heating with heating registers
- gaz burner (recommended for minimizing the operational costs)
- steam



The Product stream is sucked together with the hot air into the blower. Passing the blower, the product is turbulent contact with the hot air, and blown through a circle-shaped drying section of about 30 meters in length to create the necessary dwell time to allow the hot air to absorb the humidity. In this section a thermal sensor has been installed constantly measuring the temperature. The temperature is being displayed in the electric panel. (If heating registers are being used, the actual temperature is compared with the pre-adjusted temperature and corrected if necessary. This is achieved by switching

heating elements in the heating register on or off). Depending on the desired residual moisture and the kind of material, the temperature measured should range between 40°C and 80°C.

A pressure control device constantly checks if there is any airflow. In case of a material jam this pressure control device would react and switch off the warm air supply.

After the drying section the material goes into the separation cyclone which again separates material from the warm moist air.

TNT 250 dryer:

The material is conveyed through a circular tube arrangement. This design is for low volume throughputs.



Technical data:

Model	TNT 250	TNT 500
Blower	RMFT 75/500	RMFT 110/1000
Drive (kW)	15	37
Cyclone diameter (mm)	800	1400
Gas burner (kW)	150	300
Throughput (t/h)		
LDPE	0.3-0.8	0.5-1.5
	@3% hum.	@3% hum.
HDPE/PET	1.5-2	3.5-4
	@1% hum.	@1% hum.

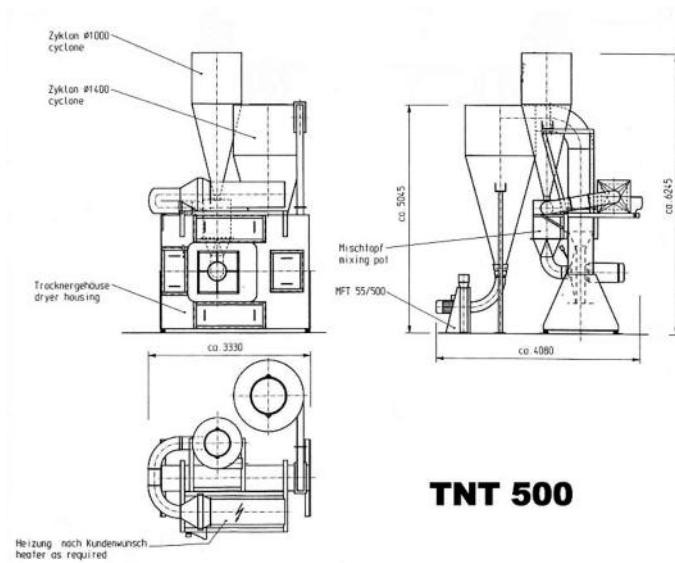

TNT 500

dimensions in mm

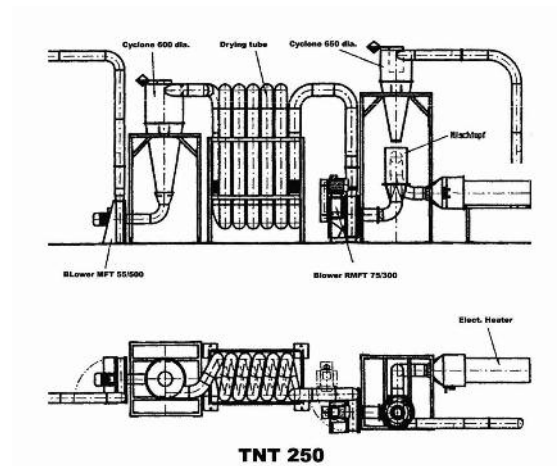

TNT 250



Our product range

- Granulators
- Pulverizing Systems
- Shredders
- Hammer Mills
- HOG Shredders
- Guillotines
- Washing Systems
- Plastcompactors

Herbold Meckesheim GmbH

Industriestr. 33
74909 Meckesheim
Postfach 1218
74908 Meckesheim
Germany
Tel.: + 49 (0) 6226/932-0
Fax: + 49 (0) 6226/932-495
E-Mail: herbold@herbold.com
Internet: www.herbold.com

Our subsidiary:

Herbold Meckesheim USA Resource Recycling Systems Inc.

130 Industrial Drive
North Smithfield, RI 02896, USA
P.O. Box 239
Slatersville, RI 02876, USA
Tel.: +1 401 597/5500
Toll-Free 888/612 RRS1 (7774)
Fax: +1 401 597/5535
E-mail: info@herboldusa.com
Web: www.herboldusa.com