

HERBOLD

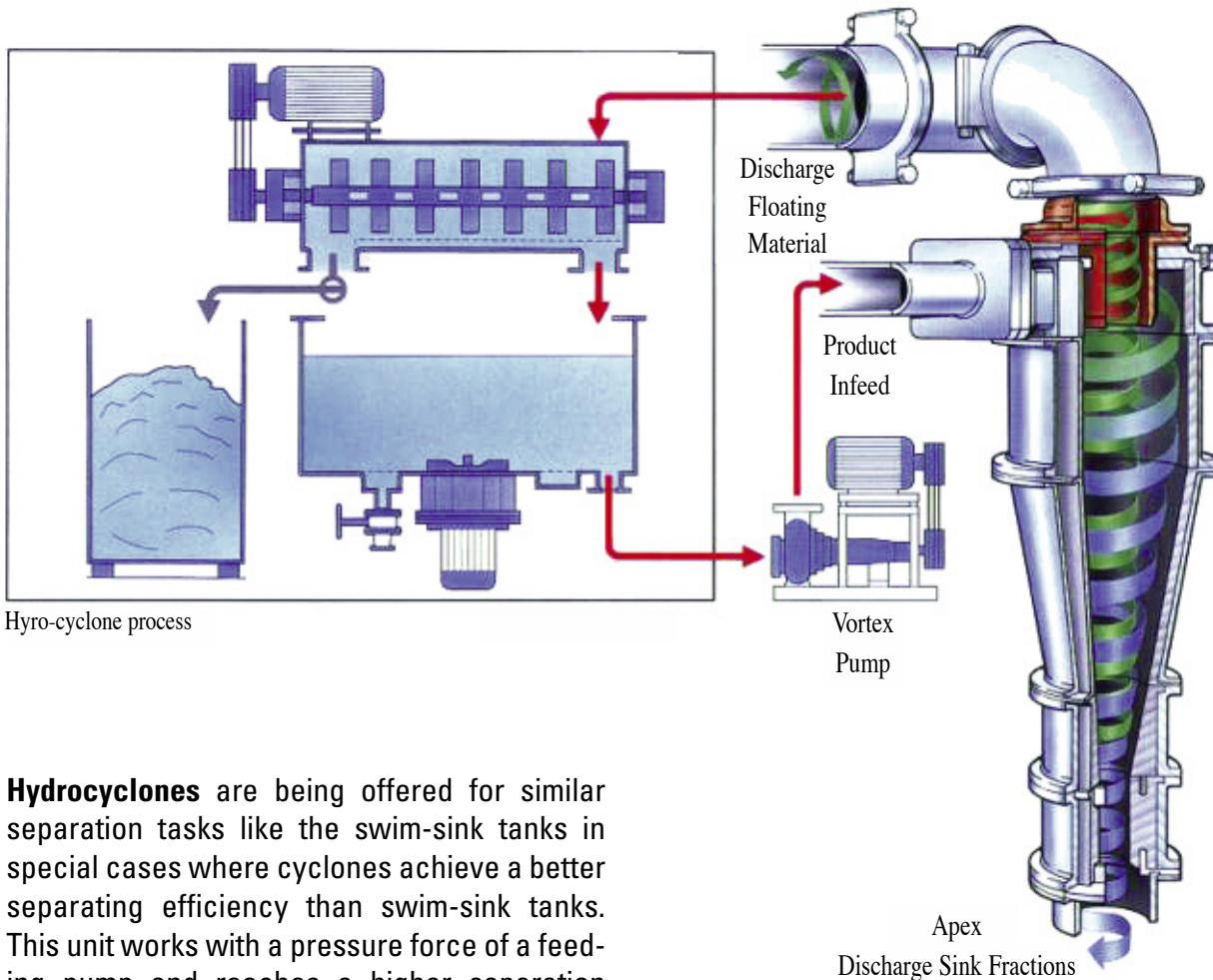

Hydrocyclones



Hydro-cyclone process

Hydrocyclones are being offered for similar separation tasks like the swim-sink tanks in special cases where cyclones achieve a better separating efficiency than swim-sink tanks. This unit works with a pressure force of a feeding pump and reaches a higher separation effect (approx. 20 times earth's gravity) by using the rotational forces of the moving water. The PE/PP material is leaving the Hydrocyclone at the upper end with the mainstream of the water, sinking material, PET, at the lower end with only small amounts of water. By choosing the nozzle sizes at the outlets of the cyclone the selectivity can be adjusted. Necessary equipment of a hydrocyclone circuit is a mixing tank (turbo washer), a feeding hydro. –

Heavy medium hydrocyclone

*H400 is a heavy duty flat bottom type cyclone for separation of glass, metal and stones in PVC or PET applications in front of a hydrocyclone. This unit comes with a discontinuous discharge with a double gate valve (pneumatically operated) and stainless steel construction.

Special Features:

- Replaceable apex on discharge
- Optional insulated cylinder housing for heated water

Technical data:			
Model	D 250	D 350	D 550
Diameter (mm)	250	350	550
Stainless steel execution	Charged extra		
Vortex Pump (kW)	15	30	45
Platform	optional	optional	optional
Throughput (t/h)			
PET / PVC	1.5	2.5	3.5
HDPE	1.5	2.5	3.5
LDPE	N/A	0.8	1.8

Units in MM

Model	A	B
D 250	852	250
D 350	1430	350
D 500	1994	500

Units in Inch

Model	A	B
D 250	33.5	10
D 350	56.3	15
D 500	78.5	20



Heavy medium hydrocyclone

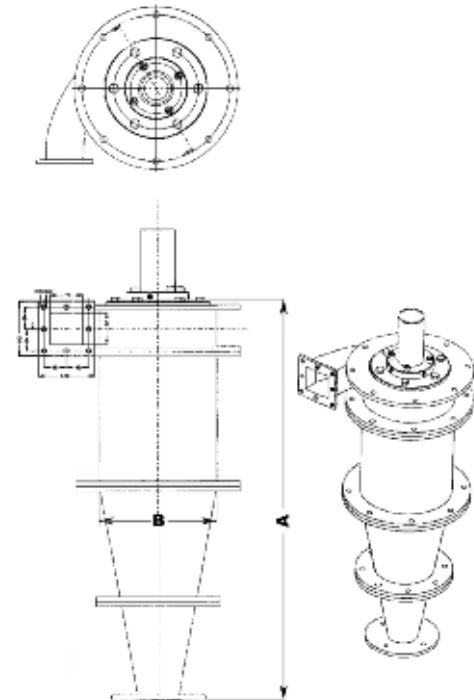

Our product range

- Granulators
- Pulverizing Systems
- Shredders
- Hammer Mills
- HOG Shredders
- Guillotines
- Washing Systems
- Plastcompactors

Herbold Meckesheim GmbH

Industriestr. 33
 74909 Meckesheim
 Postfach 1218
 74908 Meckesheim
 Germany
 Tel.: + 49 (0) 6226/932-0
 Fax: + 49 (0) 6226/932-495
 E-Mail: herbold@herbold.com
 Internet: www.herbold.com

Our subsidiary:

Herbold Meckesheim USA Resource Recycling Systems Inc.

130 Industrial Drive
 North Smithfield, RI 02896, USA
 P.O. Box 239
 Slatersville, RI 02876, USA
 Tel.: +1 401 597/5500
 Toll-Free 888/612 RRSI (7774)
 Fax: +1 401 597/5535
 E-mail: info@herboldusa.com
 Web: www.herboldusa.com