

New Cutting Device for Large Tubes: Axial Rip Saw RLS

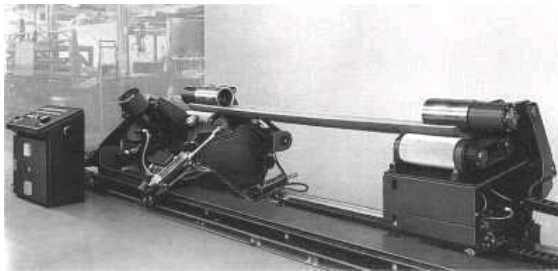

Tubes of large diameters are produced relatively seldom even by the tube manufacturers with a comprehensive assortment of products. For this reason a large granulator is out of the question.



The solution: A sawing device for cutting large diameter tubes axially into long strips that can be granulated in a standard tube granulator.

HERBOLD Axial Rip Saws for Tubes are manufactured in two sizes: For diameters from 400 mm to 1000 mm; for diameters from 400 mm to 1600 mm.

Mode of operation: A fork lift or crane positions the tube in an adjustable clamping device designed for variable diameters, thicknesses and lengths.

The clamping device rotates the tube so that it can be cut into successive strips by the circular saw mounted on a horizontal traveller.

Handling is kept to a minimum since each stage of the cutting process is automatically controlled. The power requirement for this unit is also low.

By installing the Axial Rip Saw for Tubes close to the production plant it is possible to process the waste immediately. Intermediate storage which often leads to soiling can be avoided this way.

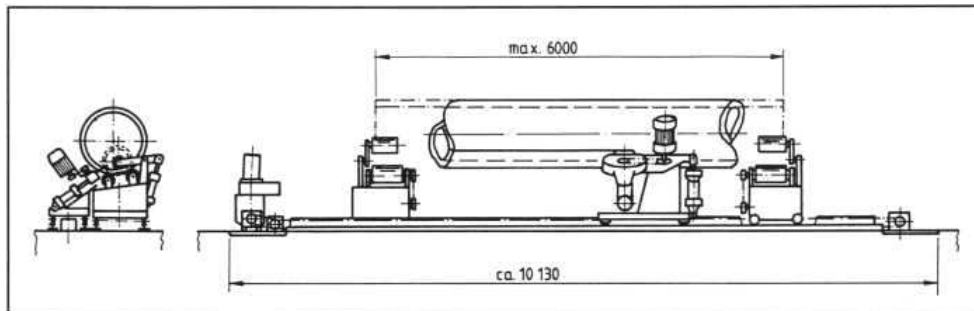
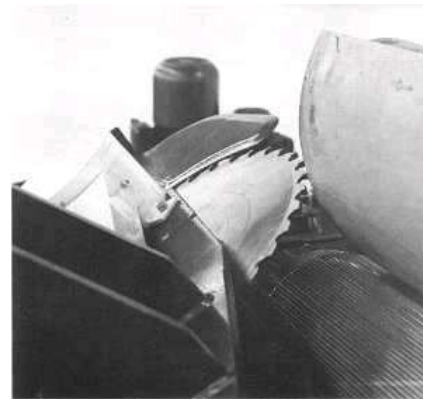

Technical data:

Length:	12 200	12 200	mm	480	480	inch
Width:	4 000	4 000	mm	157½	157½	inch
Height:	2 400	2 400	mm	94½	94½	inch
Total weight:	4 500	5 200	kg	9 900	11 400	lbs
Tube diameter max.:	1 000	1 600	mm	39	63	inch
Tube diameter min.:	400	400	mm	15¾	15¾	inch
Tube length max.:	6 000	6 000	mm	236	236	inch
Tube wall thickness max.:	75	120	mm	3	4	inch
Traveller speed:	0.65 - 3.26	0.32 - 1.63	m/min	25 - 128	12 - 64	inch/min
Installed power:	15.5	30	kW	11.4	22	HP



Our product range

- Granulators
- Pulverizing Systems
- Shredders
- Hammer Mills
- HOG Shredders
- Guillotines
- Washing Systems
- Plastcompactors

Herbold Meckesheim GmbH

Industriestr. 33
D-74909 Meckesheim
Postfach 1218
D-74908 Meckesheim
Tel.: + 49 (0) 6226/932-0
Fax: + 49 (0) 6226/932-495
E-Mail: Herbold@Herbold.com
Internet: www.Herbold.com

Our US-Subsidiary:

**Herbold Meckesheim USA
Resource Recycling Systems Inc.**
333 George Washington Highway,
USA-Smithfield,
Rhode Island 02917
Phone: + 1 401-232-3354
Fax: + 1 401-232-5425
info@HerboldUSA.net
www.HerboldUSA.net