

## Recycling of Cable Scrap



HERBOLD has developed a new type of separating unit designed to optimize the separation of plastic and metal composite material.



HERBOLD also manufactures shredders designed for feeding cable scrap with a tipping device. Call for our special brochure "Shredder Model RM". The basic unit described is for feeding pre-cut cables with a maximum length of 1 m. The HERBOLD Shredder is perfectly suited for producing this length of feed material without any manual handling.

### Advantages of the Herbold Separating Unit:

- No composite mixtures in the circulation:  
Better quality sorting and less material is required because the unit operates without return feed loop.
- Cables need not be rolled up:  
The HERBOLD separating unit processes mixed cables as well as small diameter cables.
- Easy operation:  
No special skills required for adjusting the classifier after material changes.
- Sturdy screen material:  
the Conidur screen material used by HERBOLD has a much longer working life than wire mesh screens.



Separating

HERBOLD uses granulators with double cross cutting action for the reduction of cables. The exclusive use of the very heavy duty SMS models is recommended for cable recycling plants.

Because HERBOLD leads the market as a manufacturer of granulators, it goes without saying that the HERBOLD units employ the most up-to-date technology.

#### **Advantages of the Double Cross Cutting Technology:**

- the inclined opposed angles of the rotor **and** bed knives have a positive effect upon the noise level of the unit, its power requirements and temperature generation.
- Knife adjustment takes place outside of the granulator: Shortest possible down-time. Adjustment can be carried out easily and quickly.
- The generously dimensioned design leaves power in reserve for cases of overloading, e.g. if foreign matter enters the unit.
- Standard welded construction: The granulator can be easily reconditioned by welding strengthened steel plates to parts effected by wear and tear. If required the housing can be supplied with replaceable manganese plates.
- Fracture resistant: The welded and annealed construction of the units is by far superior to cast models, particularly in cases of overloading or when foreign matter is fed.
- Outboard rotor bearings: Just forget about the frequent replacement of bearings that would be damaged by material entering directly flanged bearing units.

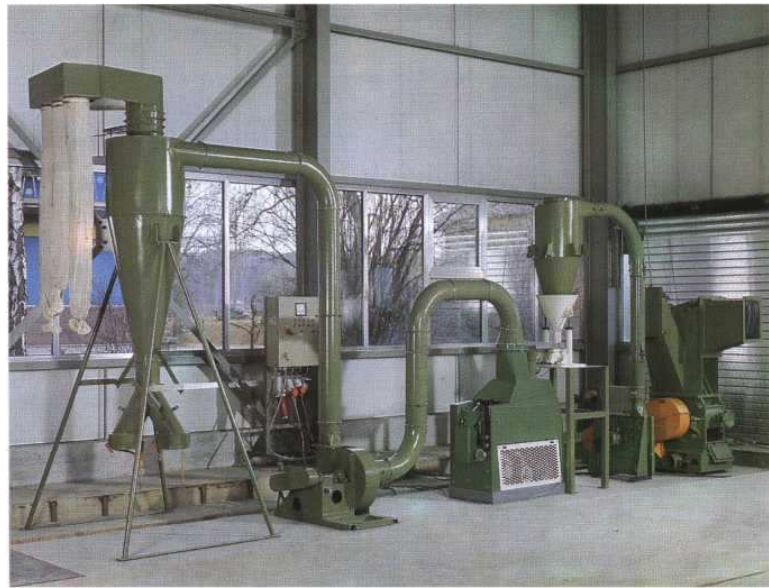
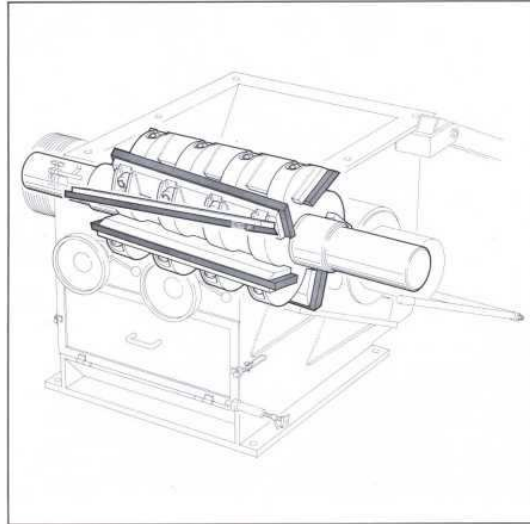

Compact unit with SMS 30/30 granulator

The HERBOLD Complete System - all details have been considered - better results and easier to service:

When compiling the complete system HERBOLD paid particular attention to its practical application: The specialist will notice that the systems have been developed with the assistances of the users and that years of experience have been put into practice here.

- **Modular design:** The system can be extended at any point of time due to higher capacities required.
- **Low line design:** This is not only significant with regards to the required building height but it also simplifies maintenance work.
- **Quick installation:** Units are pre-fabricated on chassis frames and are complete with electric cables.
- **Quality in every aspect:**

**Heavy-duty screw conveyeur with power reserves. Generously dimensioned and extremely sturdy granulators.**

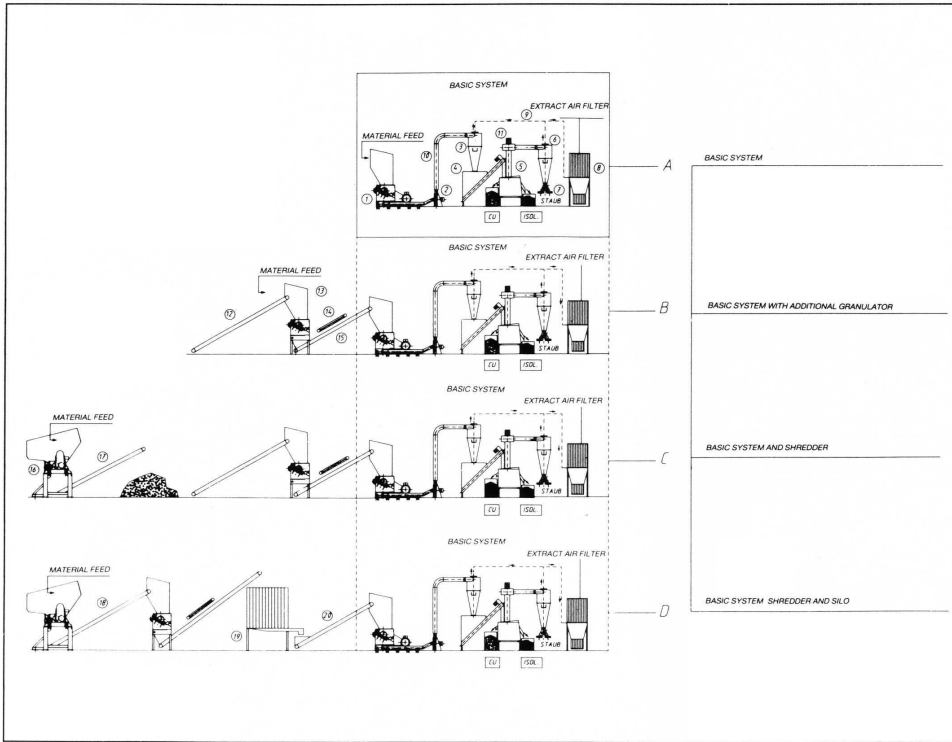

SIZE-REDUCED COPPER CABLE

HERBOLD granulators of the SMS series are heavy-duty units with power in reserve.

For further information:

Please [ask for the "SMS series" brochure!](#)



COPPER GRANULES AFTER CLASSIFICATION



PLASTIC GRANULES AFTER CLASSIFICATION



#### **Our product range**

- Granulators
- Pulverizing Systems
- Shredders
- Hammer Mills
- HOG Shredders
- Guillotines
- Washing Systems
- Plastcompactors

#### **Herbold Meckesheim GmbH**

Industriestr. 33  
D-74909 Meckesheim  
Postfach 1218  
D-74908 Meckesheim  
Tel.: + 49 (0) 6226/932-0  
Fax: + 49 (0) 6226/932-495  
E-Mail: [Herbold@Herbold.com](mailto:Herbold@Herbold.com)  
Internet: [www.Herbold.com](http://www.Herbold.com)

#### **Our US-Subsidiary:**

**Herbold Meckesheim USA  
Resource Recycling Systems Inc.**  
333 George Washington Highway,  
USA-Smithfield,  
Rhode Island 02917  
Phone: + 1 401-232-3354  
Fax: + 1 401-232-5425  
[info@HerboldUSA.net](mailto:info@HerboldUSA.net)  
[www.HerboldUSA.net](http://www.HerboldUSA.net)