

Separation tank (Swim-sink)

Swim-sink tanks use the different specific weights of the various kinds of plastics to separate them. Typical applications are the separation of PET or PVC (both sink) from polyolefines, such as PE or PP (both of them swim). The light fraction is transported along the surface of the water by means of paddle drums to a discharge conveyor; the heavy fraction are extracted – depending on its amount – either by a pair of pneumatic valves at the bottom of the tank or by a scrape conveyor mounted below the tank.

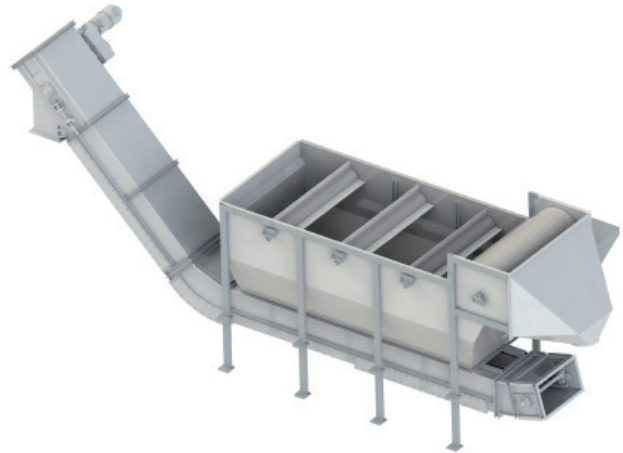

Technical data:

Separation tank (L x W)	2000 x 800 mm	3000 x 1000 mm	3000 x 1000 mm	4000 x 1800 mm
Drives (kW)				
2 transport drums	0,75	0,75	0,75	1,1
3 transport drums	/	/	/	1,1
1 Discharge drive	0,75	0,75	1,1	3,0
Total power of drives (kW)	1,1 - 1,5	3 - 4	6 - 8.	8 - 11
Discharge with scraping chain conveyor	N/A	N/A	inkl.	incl.
Throughput (t/h)				
Hard plastic	ca. 2,5	ca. 3,0	ca. 3,0	ca. 4 - 5
Film	/	0,5 - 0,7	/	0,7 - 1,0
PET flake	see separate information sheet			

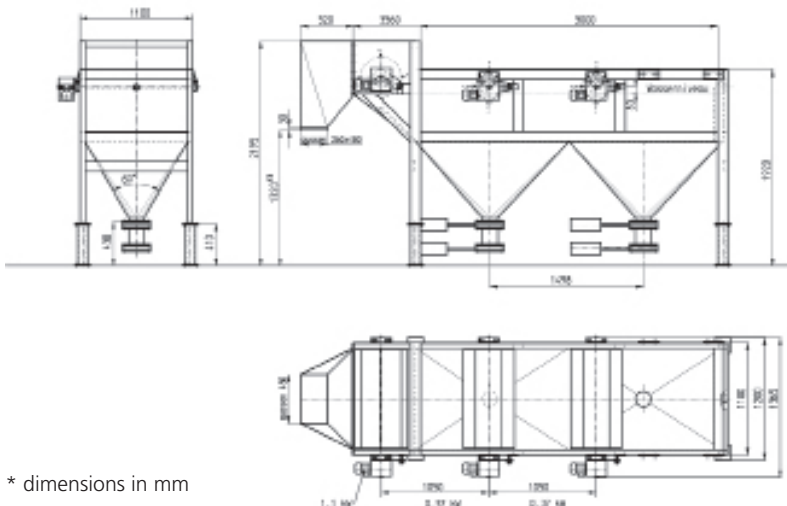

* dimensions in mm

3000 x 1000

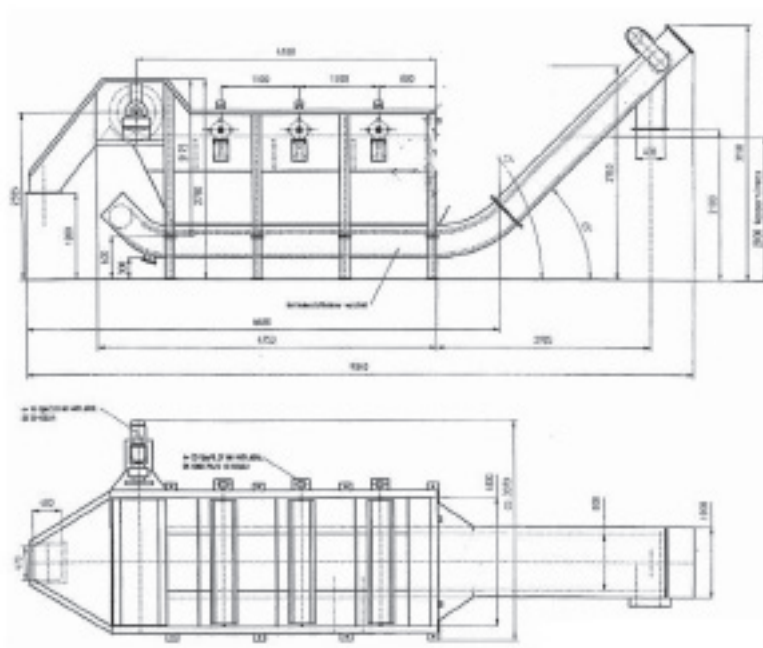
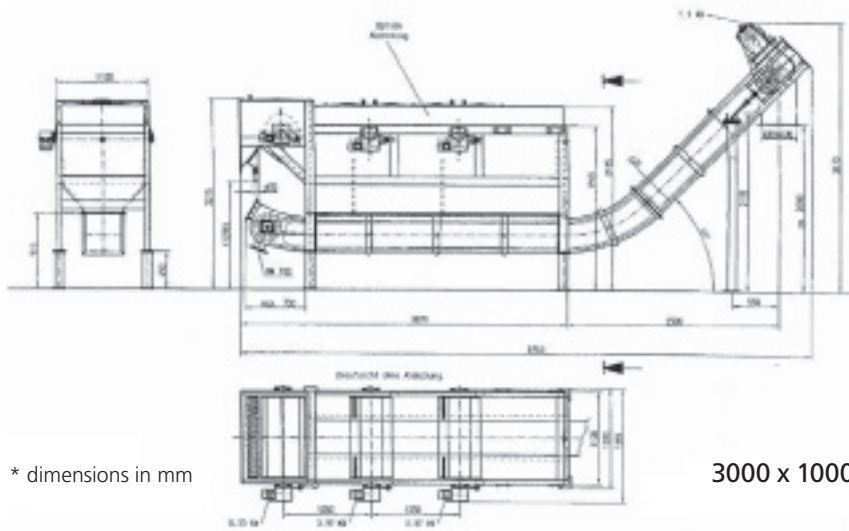

Our Product Range

Size Reduction

- Shredder
- Granulators
- Pulverizing Systems

Washing / Separation Systems & Components

- Pre-washing Units
- Friction Washers
- Separation Tanks and Hydrocyclones
- Mechanical and Thermal Drying
- Water Processing

Agglomeration

- Plastcompactors

Service

- Parts and Overhauls
- Inspections and Trouble Shooting
- Upgrades and Performance Service

Herbold Meckesheim GmbH • Fon: + 49 6226 932-0 • Mail: herbold@herbold.com • Web: www.herbold.com

Herbold Meckesheim USA • Fon: + 1 401 597 5500 • +1 888 612 RRSI (7774) • Mail: info@herboldusa.com • Web: www.herboldusa.com

Specifications are not binding and subject to change without notice. 10 / 2019