



# HERBOLD

## Special Granulators

### SML 16/... Series

With extra-wide rotor

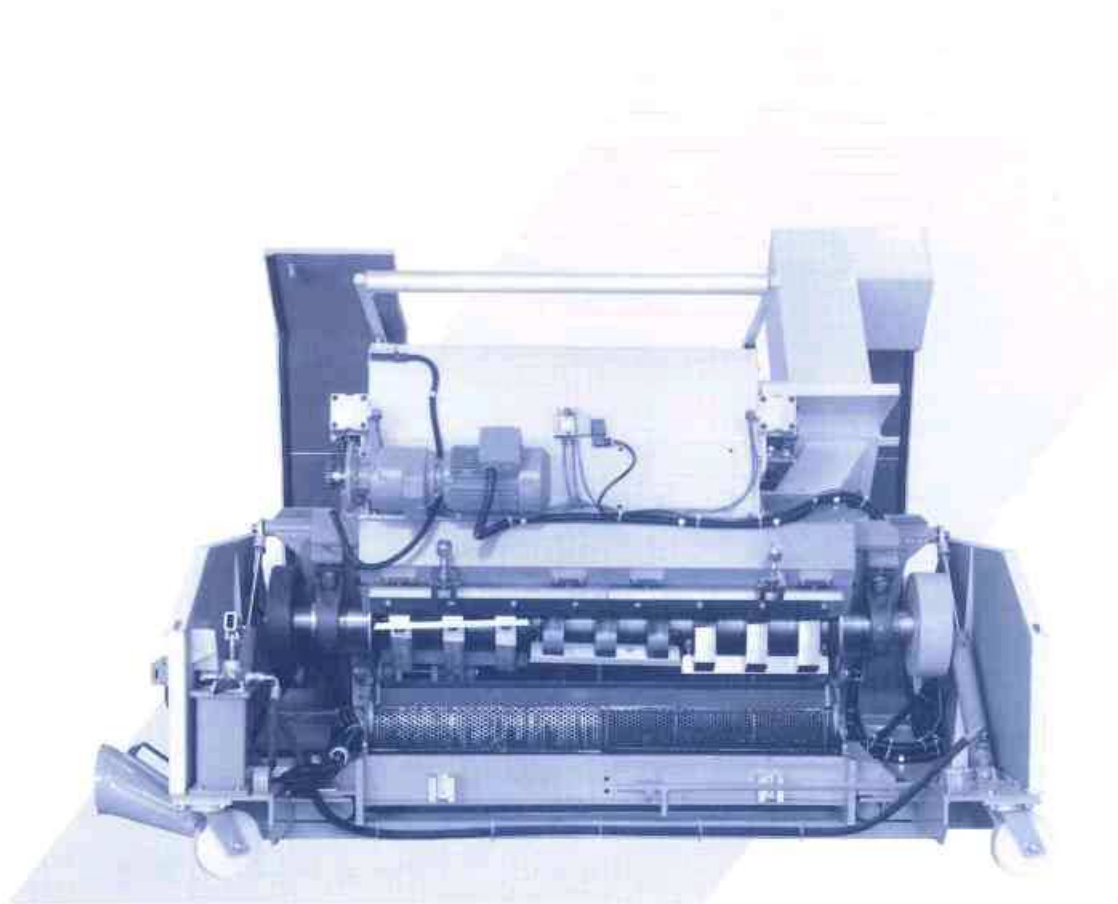

*Granulator SML 16/91*

#### Application:

- in-line grinding of skeletal waste for thermoforming plants
- size reduction of skeletal rolls
- size reduction of sheet, edge trims and flat parts

The special granulators of the series SML 16/... are available in three model types. They feature an extremely low overall height and a working width of 650 - 1350 mm (25.6 - 53.2 inches).

#### Advantageous constructional details:

- outboard rotor bearing:  
no fines can get into the bearings and no grease into the material.
- chevron-shaped cross cutting geometry:  
this knife configuration ensures low-noise size reduction with little power requirement and few fines in the material.
- preadjustable knives:  
the knives are easy to replace with a minimum of down-time.



■ totally enclosed soundproof construction with ease of accessibility.

■ mobile, compact design, can be used as an under-the-press granulator.

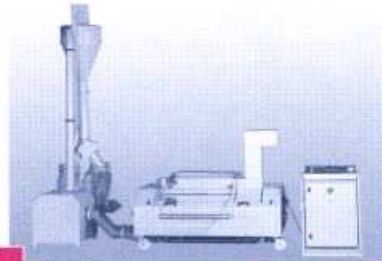

*In-line Application*

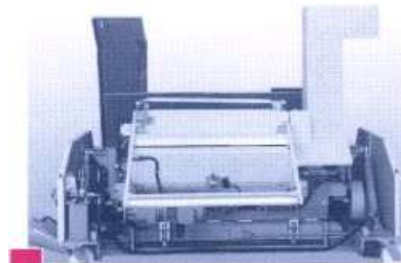
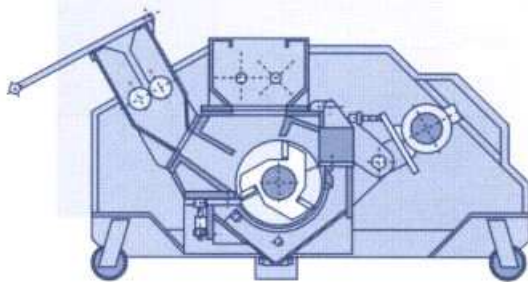

**Two different series are available:**

For in-line application

- with feed roll device for skeletal waste
- with paddle roll feeder to accept start-up with cups

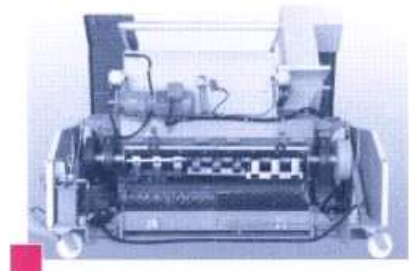

The machine can be provided with side feed hopper to accept off-spec parts (see figure above).

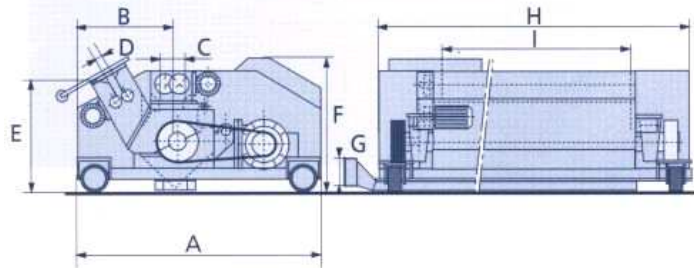

**Herbold SML 16/...**

Dimensions in mm / inches

Type	A	B	C	D	E	F	G	H	I
SML 16/61	1300	490	155	20	700	815	160	1450	650
	51.2	19.3	6.1	0.8	27.6	32.1	6.3	57.1	25.6
SML 16/91	1300	490	155	20	700	830	160	1800	1000
	51.2	19.3	6.1	0.8	27.6	32.7	6.3	70.9	39.4

## Manual Feeding

SML 16/131	1300	490	155	20	700	850	160	2150	1350
	51.2	19.3	6.1	0.8	27.6	33.5	6.3	84.7	53.2

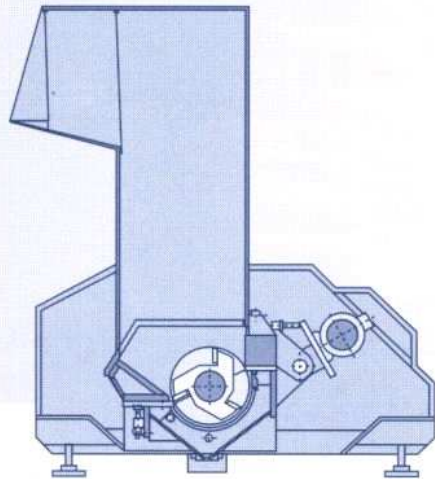

### Technical data:

Type SML	Rotor diameter	Working width	Drive	Feed opening
16/61	250 mm 9.85"	650 mm 25.6"	5,5 - 15 kW 7.3 - 20 hp	600 x 700 mm 23.6" x 27.6"
16/91	250 mm 9.85"	1000 mm 39.4"	7,5 - 22 kW 10 - 30 hp	600 x 1000 mm 23.6" x 39.4"
16/131	250 mm 9.85"	1350 mm 53.2"	11 - 30 kW 15 - 40 hp	600 x 1400 mm 23.6" x 55.2"

Specifications are not binding and subject to change without notice.

For manual feeding:

- large feeding section for rolls of skeletal waste up to a diameter of approx. 600 mm (23.6 inches).

### Herbold Meckesheim GmbH

Industriestrasse 33  
D 74909 Meckesheim / Germany

P.O. Box 1218  
D-74908 Meckesheim / Germany

Phone: +49 (0) 62 26 / 932-0  
Fax: +49 (0) 62 26 / 932-495

E-Mail: [Herbold@Herbold.com](mailto:Herbold@Herbold.com)

Internet: [www.Herbold.com](http://www.Herbold.com)

### Our subsidiary in the USA:

Resource Recycling Systems, Inc.

130 Industrial Drive  
North Smithfield, RI 02896, USA

Phone: +1 401 597 5500  
Toll-Free: 888 612 RRSI (7774)  
Fax: +1 401 597 5535

E-Mail: [info@resourcerecycling.com](mailto:info@resourcerecycling.com)  
Internet: [www.resourcerecycling.com](http://www.resourcerecycling.com)

### Our product range:

- Granulators
- Pulverizing systems
- Shredders
- Plastcompactors
- Hammer mills
- Guillotines
- Complete washing systems

