

SINGLE-SHAFT SHREDDER

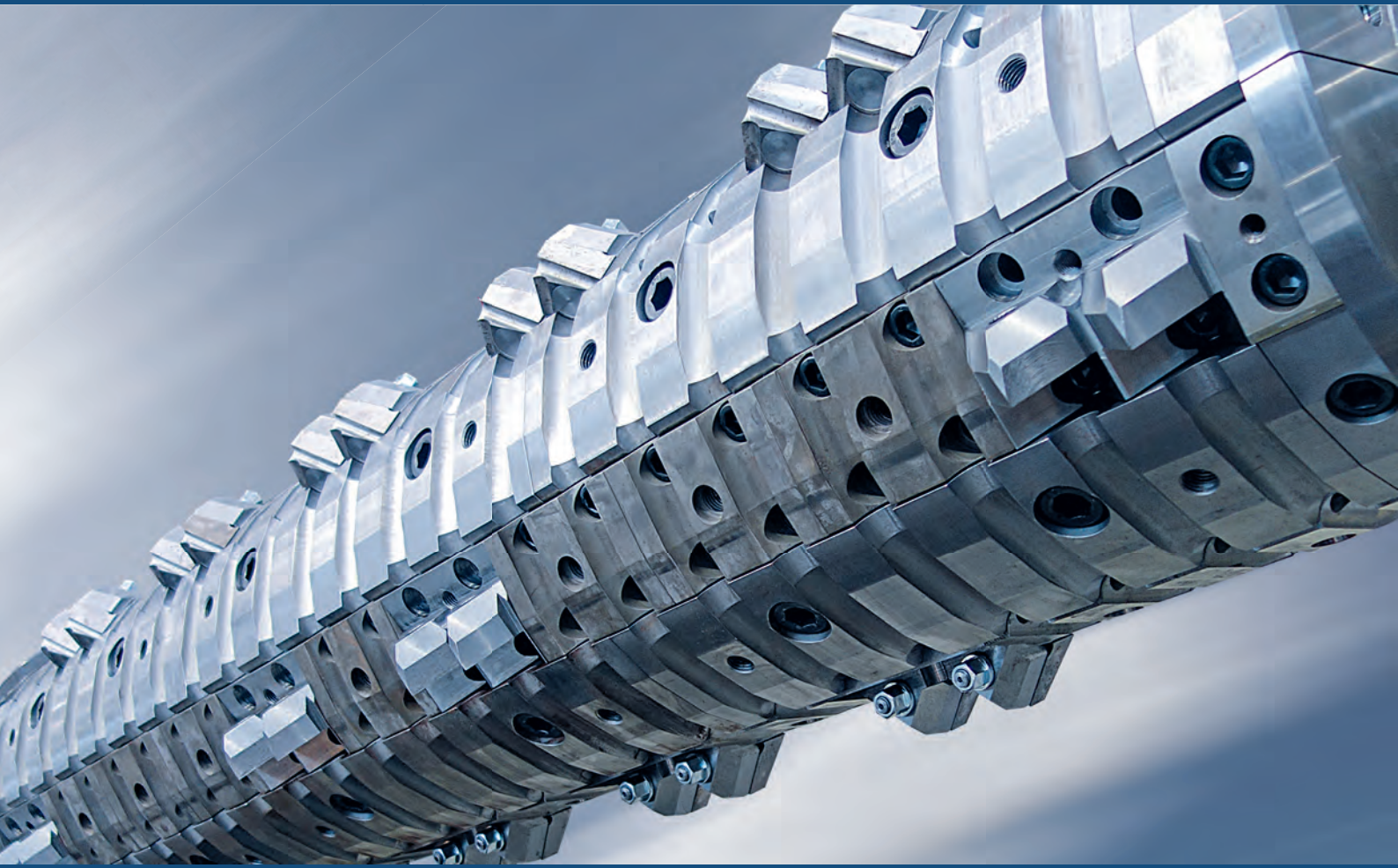

Series HR & EWS

SOLID AND INDIVIDUAL

- Robust and sturdy construction design, also for extreme demands
- Universal implementation for a wide range of materials
- Powered drive technology
- Cycle and volume dependent control of the shredding process
- Easy maintenance, fast screen exchange, reusable knives





HR 62 P HR 102 P HR 102 P with rear pressure device

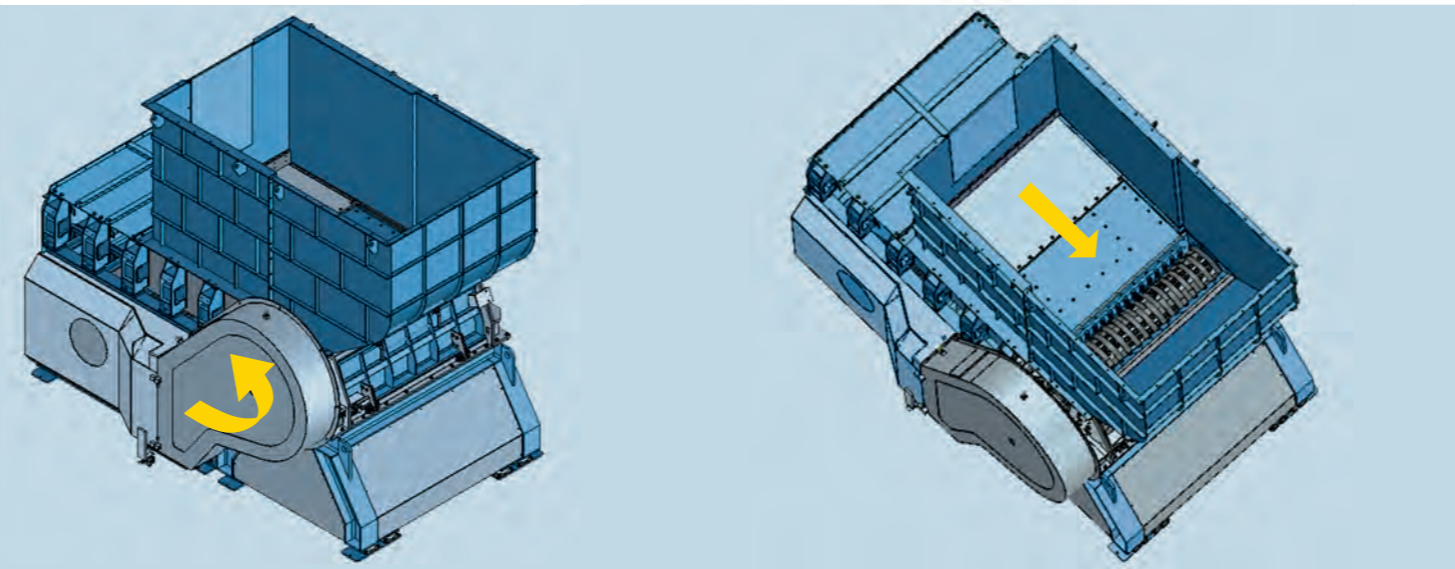

Functioning of single-shaft shredder

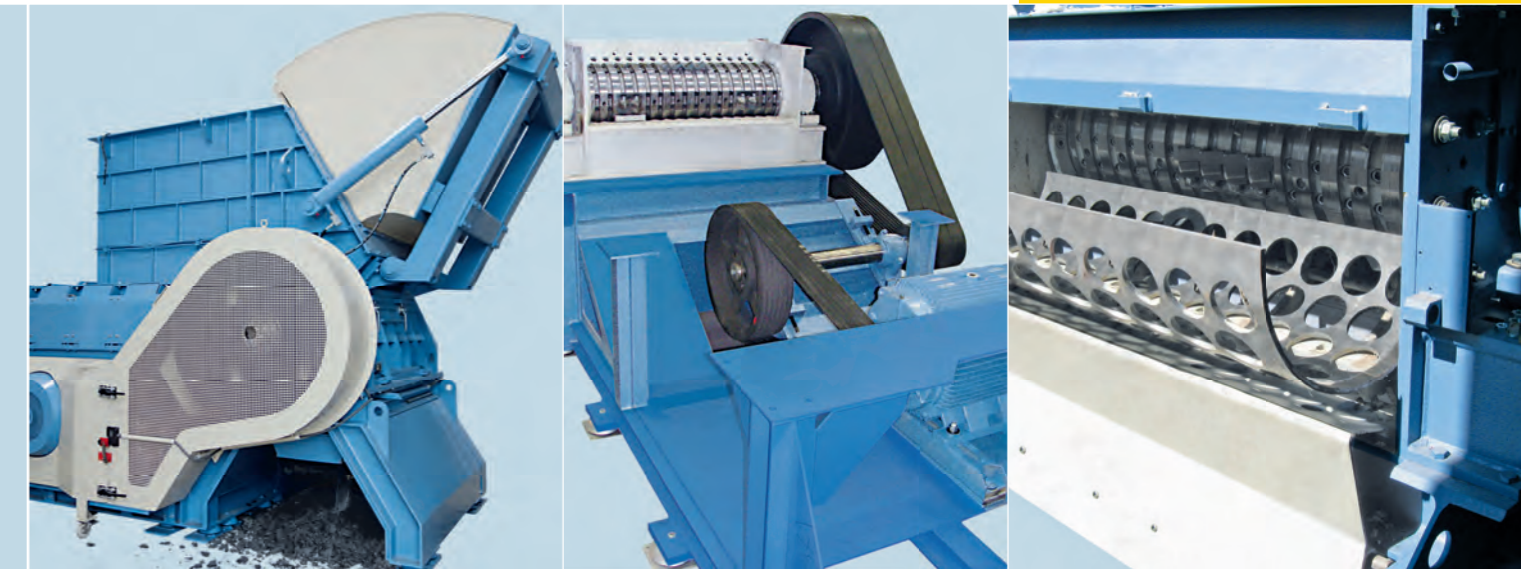

EWS 45/160 with clamping device for large hollow bodies, e.g. large trash container, IBC V-belt drive by countershaft gear instead of a drive susceptible to failure Hydraulic swivelling of screen basket, fast and easy screen change

Series HR
for small to medium capacity

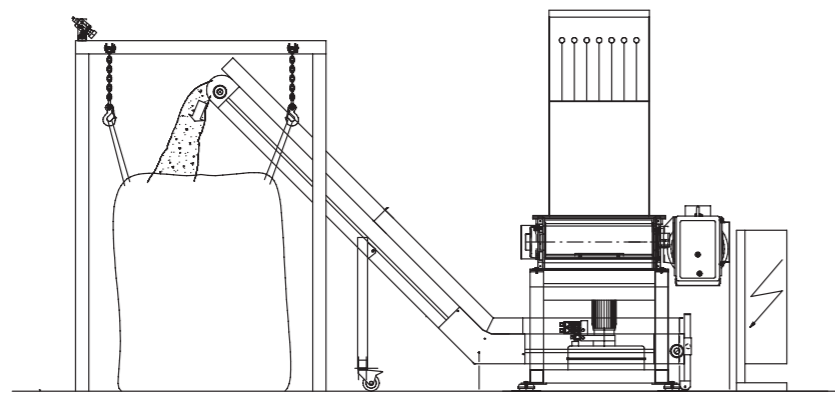

Implementation area with innovative technology

Herbold single-shaft shredders have been developed from practice for practical usage by customers. Our customers set the benchmark requirements for the innovative developments. Testing your problem materials in our Technical Center will help guarantee performance for your shredding needs.

Series EWS
for high throughput rates and difficult tasks

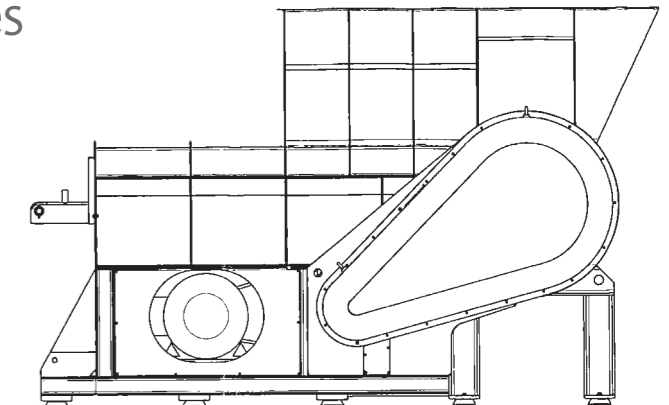

Single-shaft shredder Series HR

- Herbold single-shaft shredder of the series HR are strong, durable, and suited for tough applications and a wide assortment of materials.

HR Shredder is slow and quiet, so often no sound insulation is required. It is impervious to foreign contamination and reaches high knife life cycles. The result: Cleanly pre-cut material with low percentage of fines.

Work method:

- Once the material has been inserted (by hand, truck, or conveyor), it is pressed against the rotor via a driven feed device. This feed device is controlled by the current consumption of the drive motor. After shredding, the material is brought to the discharge channel from where it is discharged over a conveying belt, discharge screw conveyor, or discharge blower and conveyed into the system.

Superior cutting technology:

- The standard cutting devices can be used 4 times. Fast, exchangeable without high costs. Concave cutting tools are implemented for high-standard cutting performance



Benefits of the Series HR

- Slowly running and low noise, no sound isolation required
- Long life cycles of cutting tools
- Different knife designs according to material and tasks
- Neatly cut material with low percentage of fines,
- Cycle and volume-dependent control of the shredding process
- Optimal implementation of the torque allows small motor with high performance
- No extreme current peaks
- Highly insensitive to foreign bodies
- Large-volume hopper and micro process control allow fully automatic operation without operating personnel

Benefits of the Series EWS

- Flexible machine protection by belt drive
- No expensive and complicated gear damages
- Shredder shaft with variable knife number
- Quick exchange of knife mounting by cassette changing, no dismantling of the rotor required,
- Bearings of the rotor in exterior pillow block bearings completely separated from the cutting chamber so that no grease gets into the product and no shredded material into the bearings.
- Cost-efficient spare screen by separation of screen and screen basket
- Fast and simple changing of screens for different tasks and granulate sizes
- Wear protection concept for abrasive materials

Single-shaft shredder Series EWS

- Herbold single-shaft shredder series EWS are the advanced development of the standard shredder series HR, for high throughput rates and difficult tasks. The EWS consists of a heavy steel welding construction with solid design ram, exchangeable wearing plates and hydraulic swivelling of the screen basket.

Drive system:

- Optimal protection against damage by foreign bodies, due to the reduced gear drive instead of a drive susceptible to failure. With impact loads, the high inertias of the pulleys result in energy savings. The efficiency compared to a gear transmission is higher and speed variations are easy to implement.

Superior cutting technology:

- The rotor consists of variable knife numbers in easily exchangeable knife cassettes. The rotor and stator knives come in an extra-wear resistant design. Oversized spherical roller bearings have been arranged in outside steel pillow block frames completely separated from the cutting chamber. Optionally, the rotor is delivered with water cooling.

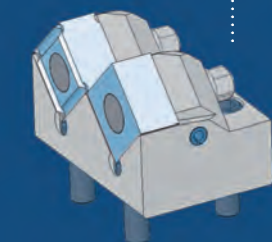

Double knife cassettes



Big bag bales

Thick-walled semi-finished products

Big waste container

Rubber tires

For pre-shredding, Herbold Meckesheim offers two series of **single-shaft shredders** for the most distinctive tasks.

Our product range

- Guillotines
- Shredders
- Hammer mills
- Granulators
- Pulverizing systems
- Washing systems & components
- Plastcompactors/agglomerators

Technical data

Type	HR 62 P	HR 102 P	HR 122 P
Rotor diameter [mm]	200	250	450
Rotor width [mm]	600	1000	1200
Inlet cross-section [mm]	1000 x 595	974 x 917	1500 x 1200
Feed cylinder stroke [mm]	550	700	1000
Weight [kg]	1250	2000	7100
Drive [kW]	18,5	30	55
Hydraulics [kW]	1,1	1,5	2,2
Rotor speed [rpm]	80	100	80
Stator knife rows	1	1 (2 parts)	1 (2 parts)
Number of rotor knives	24	38	70

Type	EWS 45/120	EWS 45/160	EWS 45/200	EWS 45/240
Standard stroke [mm]	1200	1200	1200	1200
Standard drive [kW]	75	90	132	160
Hydraulics [kW]	11	15-18,5	18,5	18,5
Stator knives	2 rows with 2 knives	2 rows with 3 knives	2 rows with 4 knives	2 rows with 5 knives
Hydraulic swivelling of screen basket	yes	yes	yes	yes
Weight [kg]	9700	13000	16000	19000
Electronic with SPS Siemens	yes	yes	yes	yes
Rotor	Universal rotor standard	Universal rotor standard	Universal rotor standard	Universal rotor standard

Special rotor designs are available for special materials such as clumps, pipes.

Subject to technical modifications



For more information, please see our videos on our website www.herbold.com

Pre-shredding

■ Pre-shredding is a required step when the feedstock is too bulky for the granulator or when coarse pre-crushing is necessary for sorting, screening or control purposes. The following pre-shredders can be implemented: Shredders, HOG shredders, guillotines and hammer mills.

Customer-oriented solution - Herbold single-shaft shredder

■ Depending on the material and requirements different screen sizes are used. The ground material produced by the shredder has a low proportion of fines and has a homogenous size.

Typical area for application:

- Recycling plants for film bales, production waste
- Film plants for rejects at intermittent and multi-layer loads
- Injection molding and blowing operations for large hollow bodies
- Problematic materials, such as sintered semi-finished product waste
- Thick-walled pipes
- Cable recycling
- DSD preparation

PE_0008



Herbold Meckesheim GmbH
 Industriestr. 33 | 74909 Meckesheim | Postfach 1218 | 74908 Meckesheim | Deutschland
 Tel.: + 49 (0) 6226/932-0 | Fax: + 49 (0) 6226/932-495
 E-Mail: herbold@herbold.com | Internet: www.herbold.com

Subsidiary in the US: Herbold Meckesheim USA | Resource Recycling Systems Inc.
 130 Industrial Drive | North Smithfield, RI 02896, USA | P.O. Box 239 | Slatersville, RI 02876, USA
 Tel.: + 1 401 597/5500 | Toll-free (US/CDN): +1 888/612 RRSI (7774) | Fax: + 1 401 597/5535
 E-Mail: info@herboldusa.com | Internet: www.herboldusa.com

All indications are not binding and subject to change. 01/2017