

HERBOLD

Beside-the-press granulators

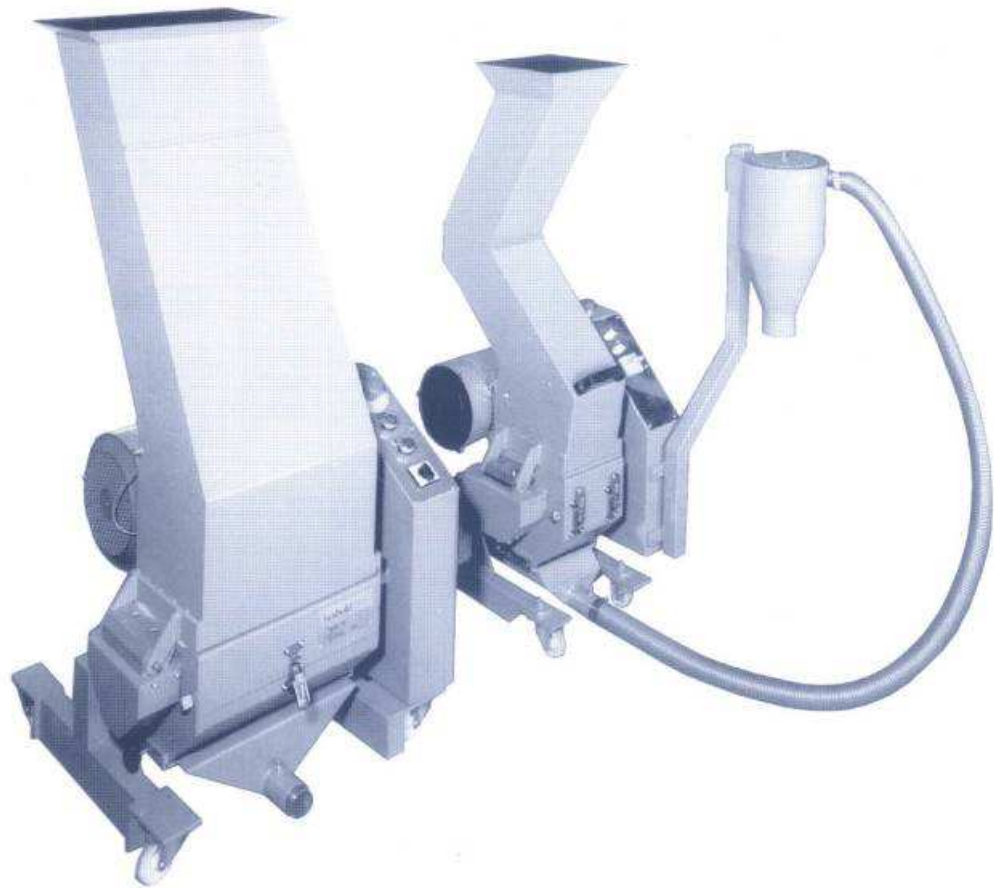

Fig.:
KG 16/35 TG
and 16/15/TG

- easy screen and knife replacement
- low-speed
- low-noise
- compact
- powerful
- rugged

Collecting, storing and grinding sprues, off-spec parts or scraps from extrusion, as it is still quite normal in many factories, is an unnecessary and dated interruption of the manufacturing process.

The beside-the-press granulators of Herbold Meckesheim GmbH are the logical link between waste disposal and production. Placed directly beside or under the production equipment in permanent operation, they save stock-keeping costs and personal expenses.

Specific feeding and disposal facilities for each application, and the large choice of accessories, allow to adapt the granulators to any production machine.

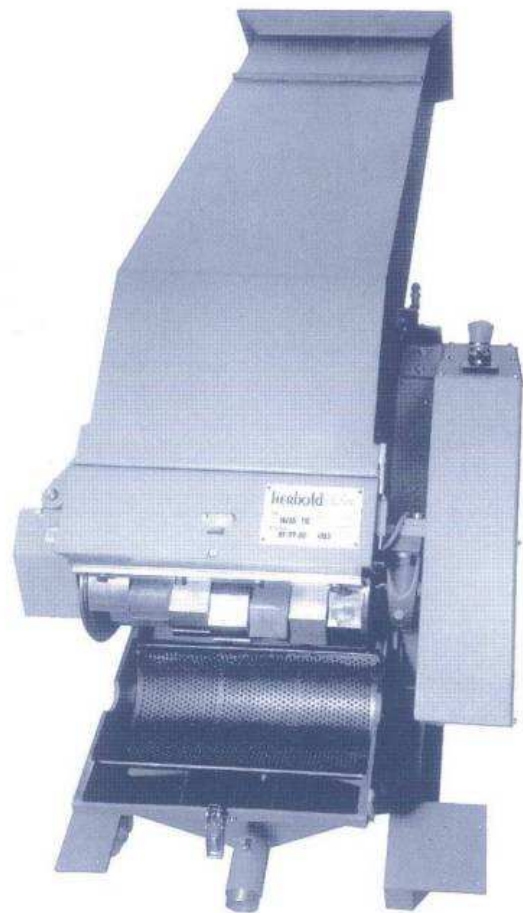

Herbold beside-the-press granulators

Model	kW	A	B	C	D	E	F	G	H
16/15 TG	1.5	180	145	425	Ø 48	515	570	175	1140
16/25 TG	2.2	180	240	520	Ø 48	515	570	175	1140
16/35 TG	3.0	180	340	610	Ø 48	515	570	175	1140
21/30 TG	4.0	220	310	1150	Ø 48	400	570	175	1140
21/35 TG	4.0	220	360	1200	Ø 48	400	570	175	1145
21/40 TG	4.0	220	410	1250	Ø 48	400	575	175	1150
21/45 TG	7.5	220	460	1300	Ø 48	400	580	175	1155
21/50 TG	7.5	220	510	1350	Ø 48	400	585	175	1160
21/60 TG	7.5	220	610	1450	Ø 48	400	595	175	1170

Dimensions A - H in mm.

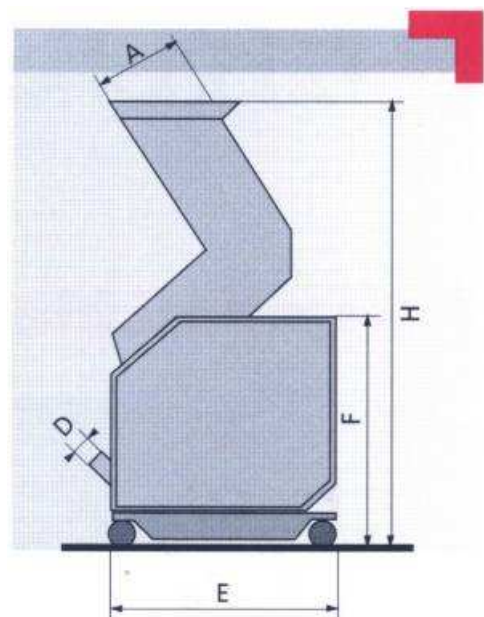

All Herbold beside-the-press granulators have the following features:

Housing:

- sturdy welded steel construction
- hingable inserts for hopper and screen tightening, secured by limit switches
- thread bushing under screen to take a capacitive sensor
- mobile by locking steering rollers with roller bearings

Drive:

- heavy-duty flat belt with three-phase motor and flywheel
- high-power gear motor with direct coupling on model KG 21/...

Cutting rotor:

- 4 cutting levels, rotor knives designed as turnable knives for double service life.

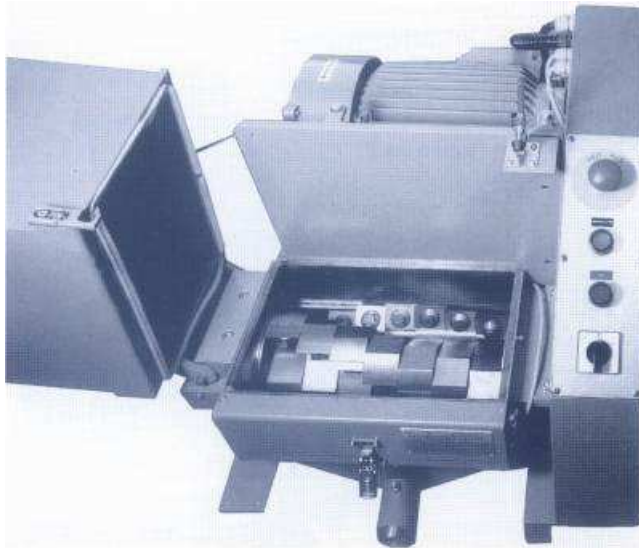
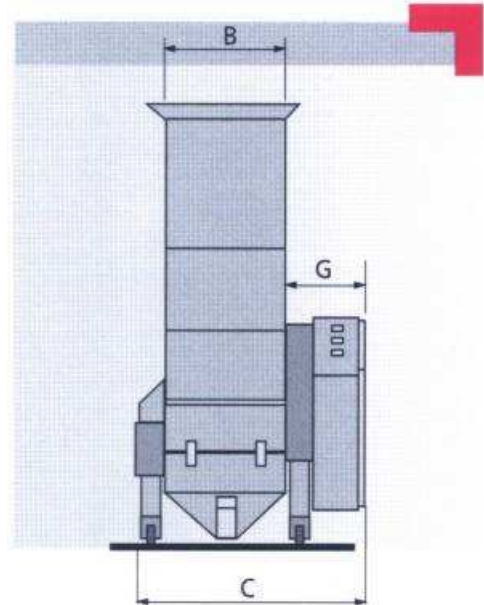

Optional features

- custom-tailored hopper variations
- mobile substructures for customers' tanks
- connecting sleeve for suction device
- sound insulation according to requirements



Specifications are not binding and subject to changes without notice.

Our product range

- Granulators
- Pulverizers
- Shredders
- Plastcompactors
- Hammer mills
- Guillotines
- Washing systems

Our US-subsiary:

Herbold Meckesheim USA
Resource Recycling Systems Inc.
130 Industrial Drive
North Smithfield, RI 02896, USA
Phone: +1 401 597 5500
Toll-Free 888 612 RRSI (7774)
Fax: +1 401 597 5535
E-Mail: Info@HerboldUSA.com
Web: www.HerboldUSA.com

Herbold Meckesheim GmbH

Industriestrasse 33
D-74909 Meckesheim
Postfach 1218
D-74908 Meckesheim
Tel.: +49 (0) 62 26 / 932-0
Fax: +49 (0) 62 26 / 932-495
E-Mail: Herbold@Herbold.com
Internet: www.Herbold.com

